

REBOUNDER™ MOUNTING INSTRUCTIONS

Hiniker 4800 Drills

(Read Instructions Completely before Beginning Installation)

Before working on your planter or drill

DANGER: when storing or working on the planter always install cylinder stops or place the planter on stands to prevent personal injury or damage to the Rebounder. **WARNING:** do not roll back or back up the planter in or on the ground as this can result in damage to the Rebounder.

Mounting Instructions

Before you begin, verify all items listed in the “package contents” table.

NOTE: See **HELPFUL HINTS FOR MOUNTING REBOUNDERS TO DRILLS.**

Step #1: place the mounting bracket for the Rebounder over the outside of the bolt hole paying attention to left or right side.

Step #2: place the bolt through the bracket, **NOTE:** some mount plates have different size holes so they may need to be re-drilled or die ground. Before tightening, raise the bracket up then tighten the bolt. This lets the Rebounder run properly in the seed V. Check from rear that Rebounder bracket is centered.

Step #3: Set the planter on the floor or, if planter is in the up position, place a board under the discs and press wheel.

Step #4: Assemble the Rebounder on the bottom side of the bracket and bolt to the bracket with 1/4 x 1” bolts.

Step #5: Position the Rebounder so that it comes within 3/8” off the floor or board under the discs.

Rebounder Package Contents (per single row)	
Item	Quantity
Rebounder	1
1/4 x 1” bolts	2
Whiz Nut	1
1/4” Nut	1
Instruction Sheet.	1
Bracket Package Contents (per single row)	
Item	Quantity
Bracket	1

Optional fittings are available for fertilizer/chemical applications. Options include, Y-Not Split-It, Hose Holder, or the Straight Shot, each available for an additional charge.

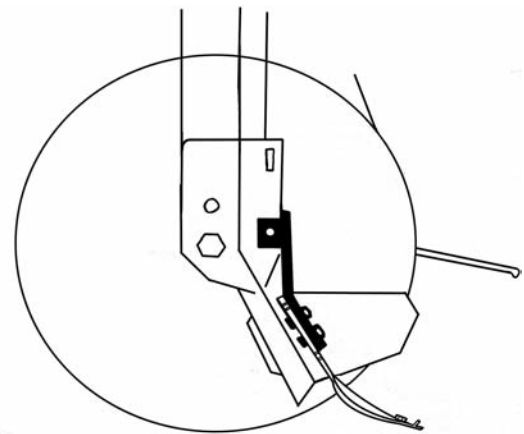
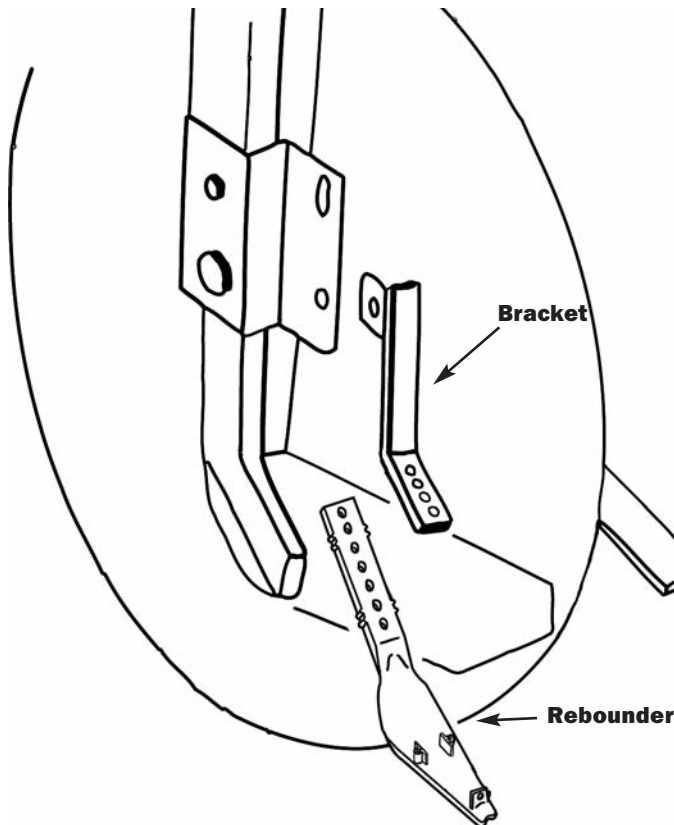

**Rebounder and
bracket mounted**

Rebounder covered by one or more of the following U.S. patents: 5,640,915; 5,918,557; 6,082,275; 6,283,050; 6,453,832; 6,763,773 and 7,121,216.

HELPFUL HINTS FOR MOUNTING THE REBOUNDER™ ON DRILLS

(Read Instructions Completely before Beginning Installation)

Before working on your planter or drill

DANGER: when storing or working on the planter always install cylinder stops or place the planter on stands to prevent personal injury or damage to the Rebounder. **WARNING:** do not roll back or back up the planter in or on the ground as this can result in damage to the Rebounder.

Helpful Hints

- Step #1:** use a farm jack on the press wheel to raise up the drill unit 3-4" before you mount the first row.
IMPORTANT: have press wheel adjusting handle of knob, in the position you would normally run in the field (see **fig (a)**).
- Step #2:** slide a board or piece of flat iron under the double disc openers and back under the press wheel tire. The board or flat iron represents the bottom of the seed V.
- Step #3:** now you can bolt the Rebounder to the bracket on the drill. Position the Rebounder on the bracket so that the trailing end will be from 3/8" - 1/2" off the board or flat iron. Using the 1/4" bolts attach the Rebounder to the bracket on the drill.
- Step #4:** variances in the disc blade size will occur among individual drills as well as within any single drill. Measure discs behind the tire track rows. If they are worn more than other rows this process may need to be used to set these rows also.
- Step #5:** if replacing Rebounders on previously installed brackets, simply remove the old Rebounder without removing the disc blade. Using a small bar magnet or a long handled magnet, place the bolt on the magnet and slide it up between the discs and into the holes of the bracket and the Rebounder. This allows you to come in behind with a wrench or socket to install and tighten the nuts.

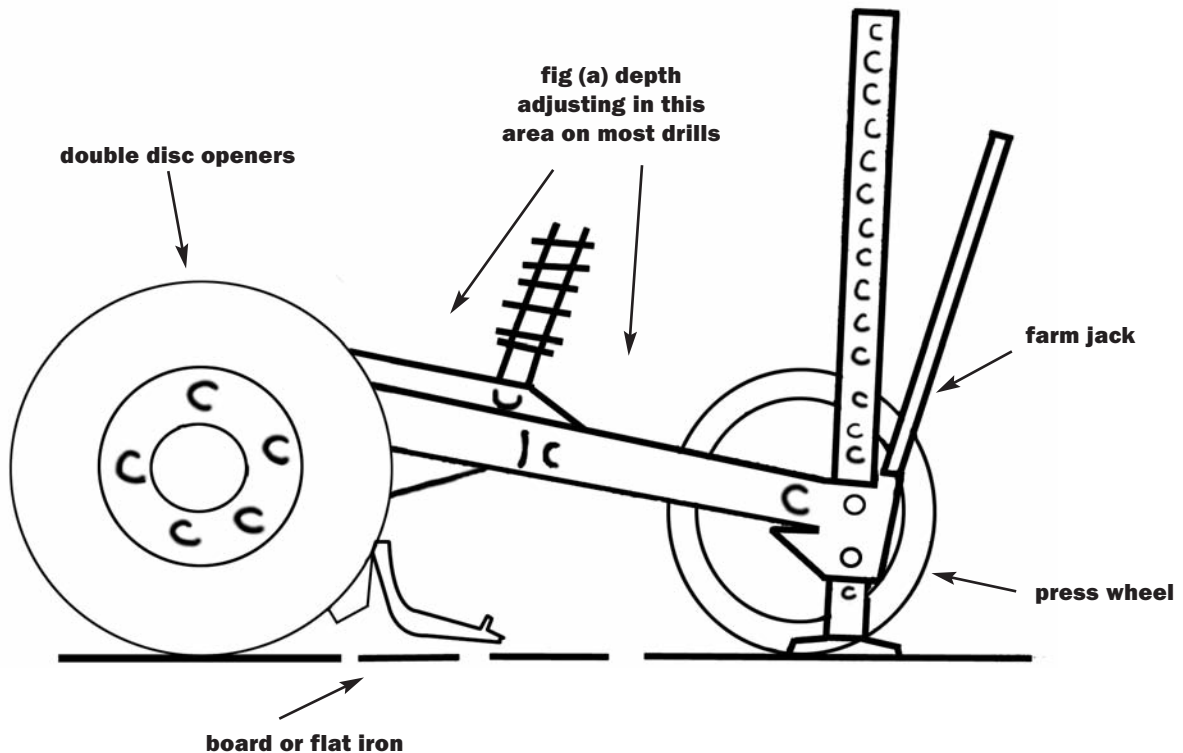

Rebounder covered by one or more of the following U.S. patents: 5,640,915; 5,918,557; 6,082,275; 6,283,050; 6,453,832; 6,763,773 and 7,121,216.