

**THREE OTHER APPLICATION OPTIONS FOR CHEMICAL/FERTILIZER/MICRO-N/INOCULANTS OR FUNGICIDES ON SEEDS IN THE FURROW**

Optional Fitting for Rebounders - J.D., Kinze, White, Yetter, Great Plains, Monosem Planters, most No-Till or Conventional Drills, and IH Type Planters and Drills

(Read Instructions Completely before Beginning Installation)

**Two Options**

- Option #1: molded-in tab (fig. (a))** - the molded-in tab is used when you want to put fertilizers, insecticides or inoculants in the proximity of the seed. This option can sometimes cause mud or fertilizer to build up on the press wheels that run in or over the top of the seed furrow.
- Option #2: quick coupler #1 (fig. (b)) and strapped hose (fig. (c)) or the (fig. (d))** - quick coupler #1 elbow and strapped in hose are used in place of the molded-in tab option, and the **NEW Straight Shot (fig. (d))** - Refer to Straight Shot Mt. Instructions on separate sheet. These options help eliminate fertilizer buildup on press wheels. These options put liquid in the vicinity of the seed for better seed to soil contact. These options also keep the fertilizer from building up on the 1" X 13" or 2"x13" drill press wheels that run in the seed furrow.

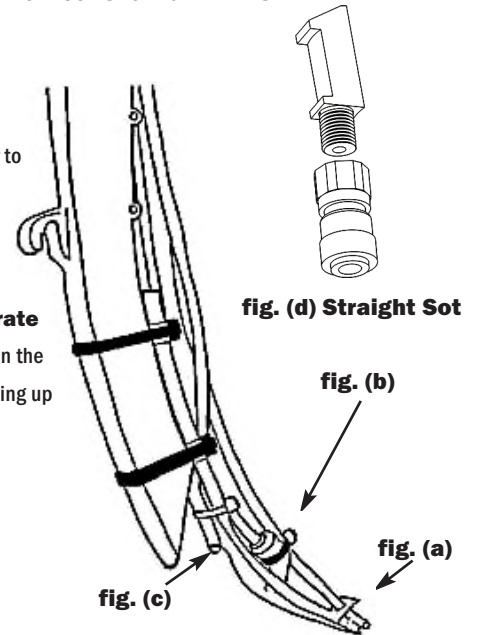

**Quick Coupler Mounting Instructions**

**OPTION A**

**Step #1:** if you want liquid placed closer to the seed drop, measure up 2 1/4" from the molded-in tab on the Rebounder.

**Step #2:** with a pen make a mark in the center of the Rebounder for a 11/32" hole to be drilled. Tap the hole with a 1/8" NPT threader.

**OPTION B**

**Step #1:** if you want liquid further away from the seed, measure up 1" from the molded-in tab directly between the Y-Not holders. Drill an 11/32" hole, using an 1/8" NPT tap thread, for quick coupler #1 elbow to screw into. After QC #1 has been threaded into the hole, put 2 screws in Y-Holders to keep the QC#1 from twisting sideways (**fig.(e)**).

