

JD DRILL OPTIONAL FITTINGS

STAINLESS STEEL TUBES

- ▶ Works with Rebounders, planters and drills
- ▶ Effective liquid placement
- ▶ Durable, rust-free stainless steel
- ▶ Easy installation
- ▶ Great for starter application

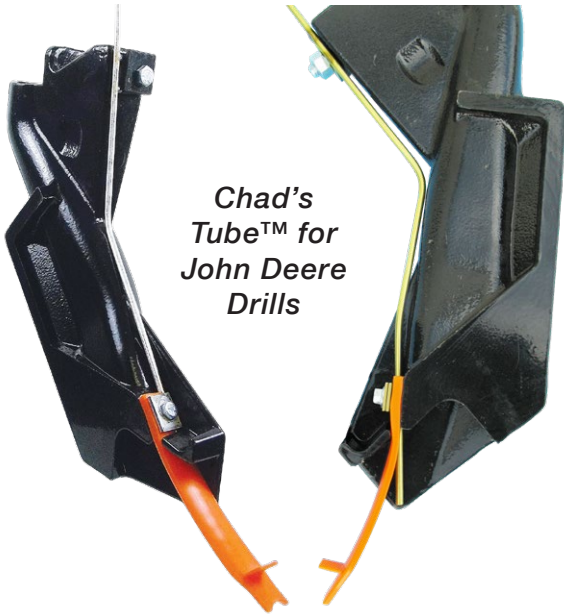

BENEFITS OF TUBE OVER THE PRESS WHEEL

- ▶ Places fertilizer behind the press wheel for a cleaner drill
- ▶ Rebounder's concave design places all the seeds in the bottom of furrow
- ▶ The press wheel presses seeds in before fertilizer is placed above the seed
- ▶ Bracket models fit the 9" (SDX & JD type) press wheel



Tube for John Deere 9" Press Wheel

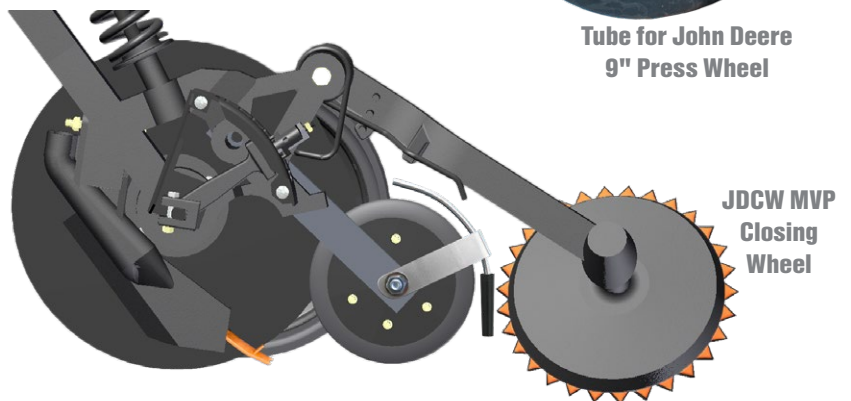

JD 750 Drills have 10" press wheels. We sell 9" wheels for replacements.

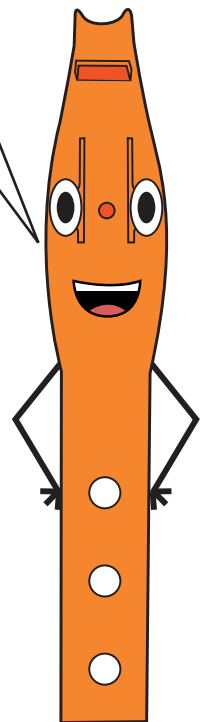
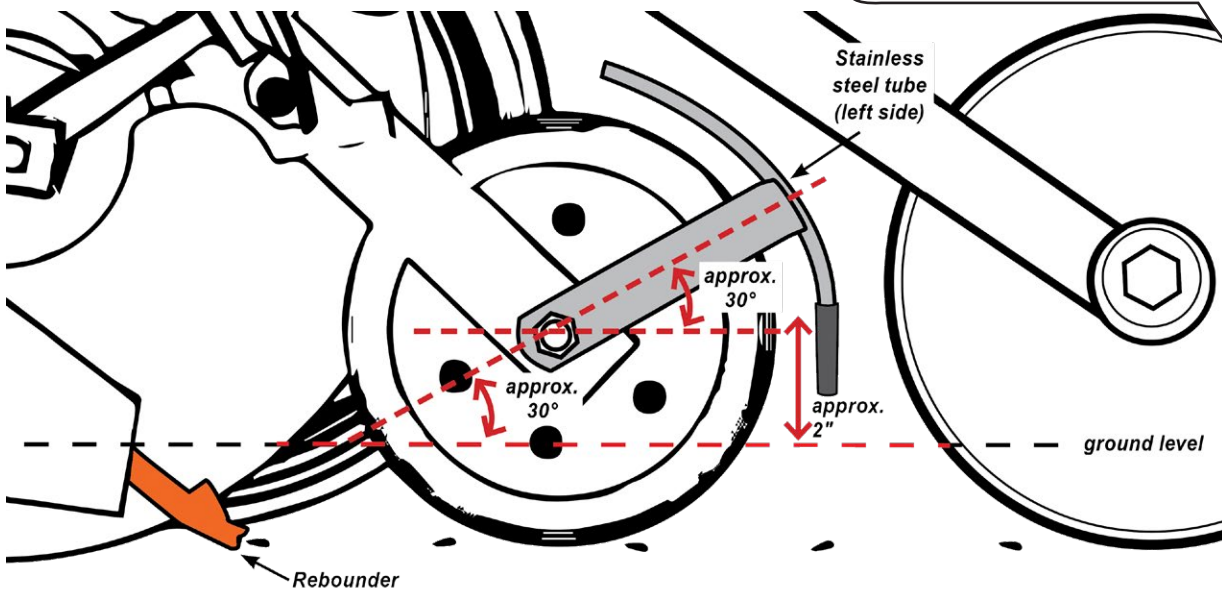

WWW.SCHAFFERT.COM

Schaffert
manufacturing & sales

71495 ROAD 397
INDIANOLA, NE 69034
SALES@SCHAFFERT.COM

308-364-2607
800-382-2607