

**T.D.I FERTI-PLACER MOUNTING INSTRUCTIONS**

**Case IH Planters**

(Read Instructions Completely before Beginning Installation)

**Before working on your planter or drill**

**DANGER:** when storing or working on the planter always install cylinder stops or place the planter on stands to prevent personal injury or damage to the attachments.

**Mounting Instructions**

Before you begin, verify the “package contents” to ensure all items are included.

**Step #1:** remove axle bolt on the left side of the packer wheel. Mount side bracket using the 3/8 x 1” bolt, 3/8” LW, 3/8 nut, 1/2” x 1” bolt, 1/2” LW, and 1/2” nut. For the new IH 1200 2005 model planters. In 2005, Case IH started using 5/8” bolts for the press wheels. If you have older than 2005, the Ferti-Placer bracket holes will be 1/2” holes and will need to be drilled out to 5/8”.

**Step #2:** mount the Ferti-Placer on the right side of the planter bracket in the highest position. Mount using the provided 3/8 x 1 “ carriage bolts, 3/8 flat washers, and 3/8 top lock nuts to mount the square shaft bracket to the Ferti-Placer bracket.

**Step #3:** adjust in the field. Lower the planter to the ground and drive forward approximately 2 feet. Loosen the carriage bolts on the ferti-placer and move attachment down until there is slight spring tension. Then slightly tilt the Ferti-Placer back to an approximate ten degree angle. Re-tighten the carriage bolts. Drive the planter several more feet forward and do the final adjustments if needed. After several hours of usage, re-tighten all nuts and bolts. You may want to weld brackets in place if they come loose once they are set.

**NOTE:** for non-usage or storage, simply push the Ferti-Placer up and insert a cotter pin in the hole in the square shaft for the raised position. Raised position can also be used to apply fertilizer in fields with heavy un-manageable residue or some loose worked ground.

Ferti-Placer Package Contents (per single row)	
Item	Quantity
Metal Bracket .....	1
Spring Cushion Bracket* .....	1
Poly Block* .....	1
Knife* .....	1
<b>THE FOLLOWING ARE USED TO ATTACH THE FERTI-PLACER TO THE BRACKET</b>	
3/8” x 1” carriage bolts .....	2
3/8” flat washers .....	2
3/8” top lock nuts .....	2
<b>THE FOLLOWING ARE USED TO ATTACH THE BRACKET TO THE PLANTER</b>	
3/8” X 1” bolt .....	1
3/8” lock washer .....	1
3/8” nut .....	1
1/2” x 1” bolt .....	1
1/2” lock washer .....	1
1/2” nut .....	1
<b>THE FOLLOWING ARE USED TO ATTACH THE HOSE TO THE TOP OF THE FERTI-PLACER</b>	
5/8” tube clamp .....	1
3/8” x 1 1/4” bolt .....	1
3/8” nut .....	1
Instruction Sheet .....	1
*NOTE: some hardware is installed at the factory.	

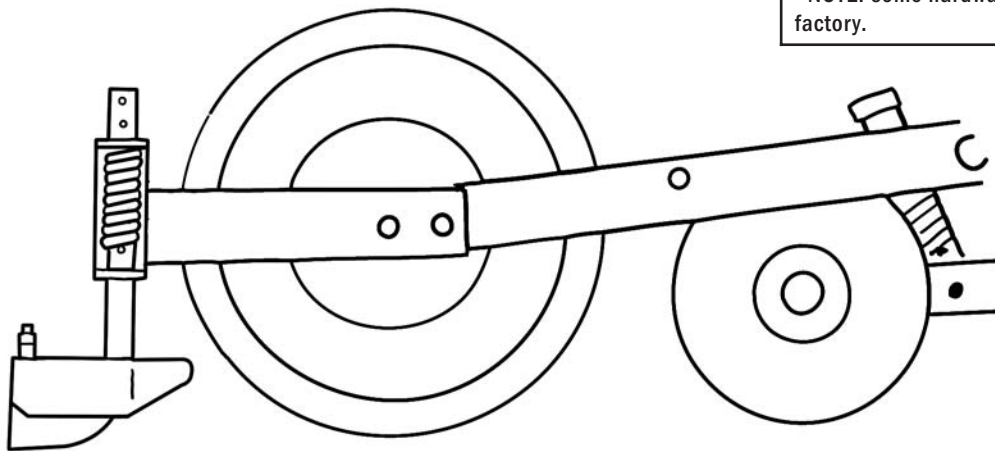

**Ferti-Placer on IH Planter**